

C-10 Series -ピッチ (Center Pitch) 2.54mm-

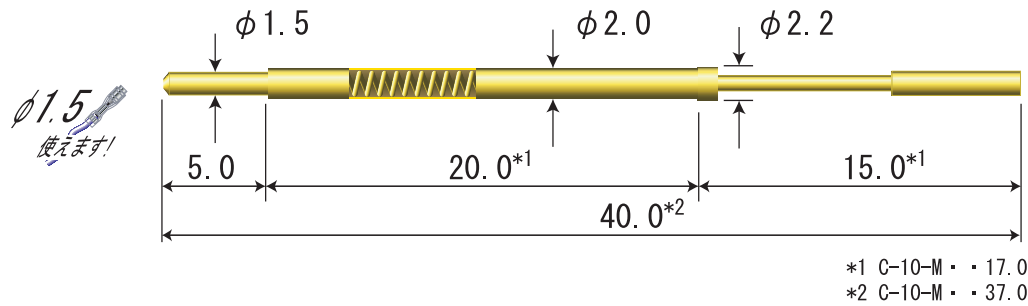

先端形状<Tip Style>

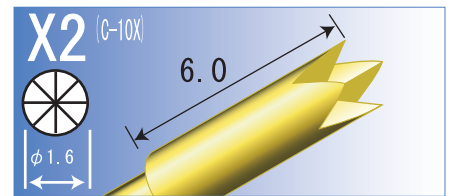
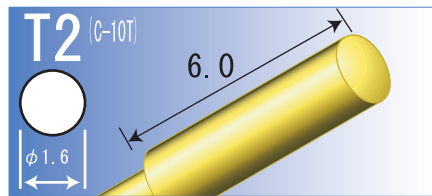
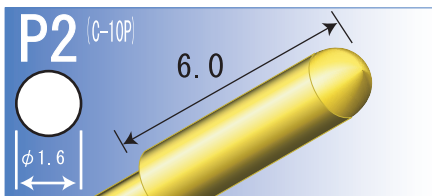
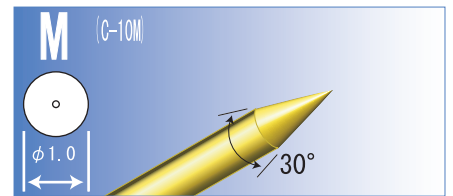
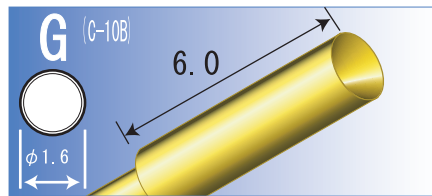
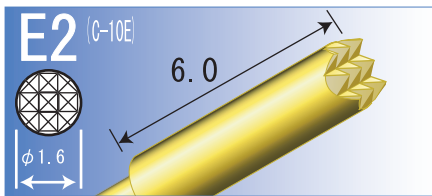
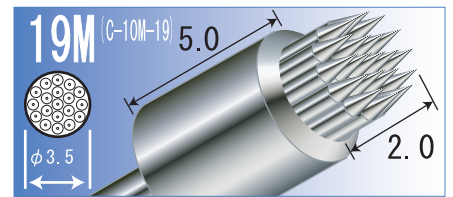
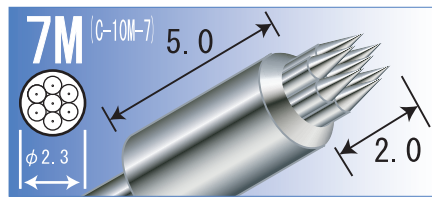
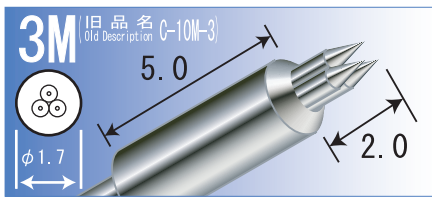

材質・表面処理/Materials

プランジャー : SK材、Ni又はNi下地Auめっき
 スモールピン : SWPA、Niめっき
 ヘッド(スモールピン) : 真鍮、Niめっき
 スプリング : SWP又はSUS
 スリ ー ブ : 真鍮、Ni下地Au又はNiめっき

Plunger : Nickel or Gold over Nickel plated High Carbon Steel
 Needle : Ni plated Hard Steel wire
 Head (For Needle) : Ni plated Bs
 Barrel : Nickel or Gold over Nickel plated B.S.T.
 Spring : Music Wire or Stainless Steel

バネ圧/Spring Force

品名 Type	最大 ストローク Maximum Travel	推奨 ストローク Recommended Travel	推奨時 荷重 Rated Force	初期圧 Preload
C-10-3M	6mm	4mm	260g	65g
C-10-7M	6mm	4mm	260g	65g
C-10-19M	6mm	4mm	260g	65g
C-10-E2	7mm	4.6mm	220g	25g
C-10-G	7mm	4.6mm	220g	25g
C-10-M	7mm	4.6mm	220g	25g
C-10-P2	7mm	4.6mm	220g	25g
C-10-T2	7mm	4.6mm	220g	25g
C-10-X2	7mm	4.6mm	220g	25g

シリーズ 先端形状
Series Tipstyle

C-10 -

例
Example C-10-D2、C-10-7M